

Clarte'[®]

Home Comfort Center

INSTRUCTION MANUAL CHOPPER

Please read these instructions carefully before using the unit.

Model : FMX020L

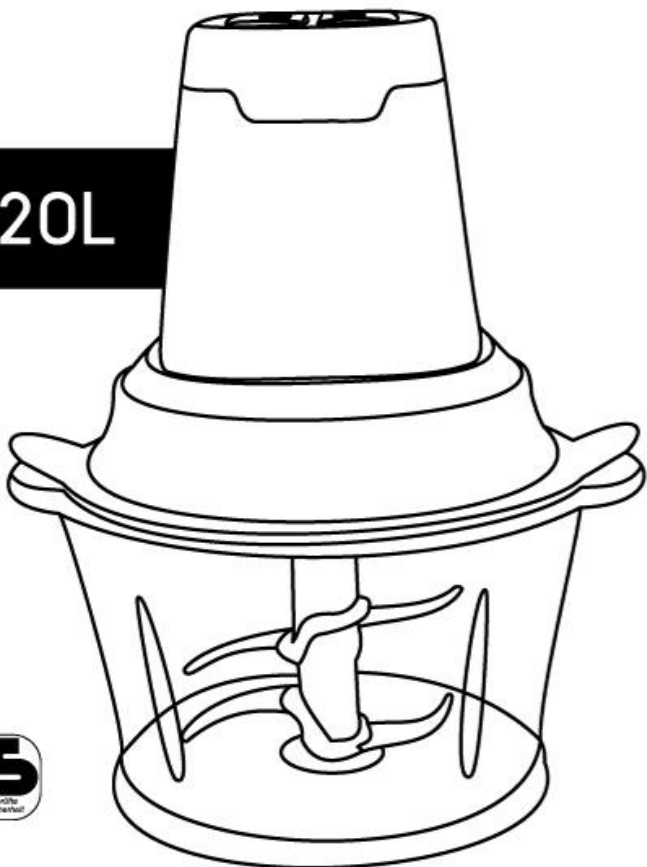

SES
SMART ELECTRICAL SUPPLIES

52,54,56,58,60 Soi Phrayasuren 30(Soi Saengsri), Phrayasuren Rd.,
Bangchan, Klongsamwa, Bangkok 10510, Thailand.

Tel. (66)2-919-2311 , FAX. (66)2-919-2400, www.clartethailand.com

PARTS

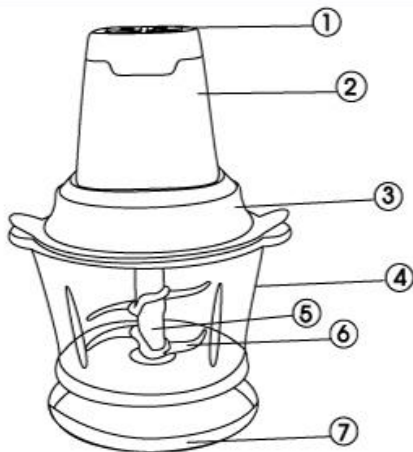

- | | |
|------------------|---------------------------|
| 1. ON/OFF Button | 5. Stainless Steel Centre |
| 2. Motor Base | 6. Blade |
| 3. Cover | 7. Support Rubber |
| 4. Glass Bow | |

SPECIFICATION

Capacity : 2.0 L	Power : 250 W
Voltage : 220-240V	Frequency : 50-60Hz

IMPORTANT SAFEGUARDS

- Please read all instructions before using the appliance.
- This product is for household use only.
- Make sure that the marked voltage of this product is in conformity with the input voltage.
- Children is not allowed to use this product without close supervision.
- If the power cable is damaged, it must be replaced by the manufacturer or the manufacturer's customer experience in order to avoid all risk.
- Unplug from outlet when not in use and before cleaning and when repairing the components.
- Do not use outdoors.
- Do not place on or near a hot gas or electric burner or in the high humidity. Avoid direct sunlight.
- Do not touch the blades until the product is power off and the blades stop working.
- Unplug from outlet before taking out the food.

CAUTIONS: - Idling is forbidden.



- The blades are very sharp, so water must be clean enough for you to see the blades when cleaning.
- Company will not be responsible for damage case by misus or improper user or do not follow this instruction manual.

Note: Some details of the products in this manual may differ from the actual products which may be caused by the mistake in printing this instruction manual. The Company reserves the right to update or modify any part of actual products which may be considered appropriate. Please contact our customer service for more information.

Before using

Take out all material and clean the bowl and cover.

INSTRUCTIONS

1. Remove the motor base and cover, place the bowl on a flat and clean place.
2. Place the blades on the axis in the middle of the bowl.
3. Cut the food into small pieces before putting them into the bowl.



No bone should be put in the bowl when stirring in case the damage of the blades.

4. Place the cover.
5. Place the motor base on the cover in the right place and connect the power plug.
6. Push down the button, the product works and when not push the button, then it stops.
7. After finishing stirring, unplug the outlet and remove the motor base after it stop working, and take out the food.

TIPS

- When the cover or motor base is not perfectly placed, the product will not work.
- This product cannot be used to stir the frozen food, unfreeze the food before stirring.
- Well place the blades before putting the food into the bowl, if the blades do not work or work slowly, unplug the outlet and check if there is barrier in the bowl.
- This product has over temperature protection system, over time working will lead to power off automatically. Please unplug the outlet and allow the appliance to cool.

CLEANING

- **Unplug the outlet before the cleaning.**
- Do not immerse the power cord and motor base in water or other liquids.
- Do not use rough material to wash the bowl or cover.
- Pour some warm water with a little cleanser essence into the bowl, and operate the product for a few seconds, then clean it up with clean water.
- Before assembling, check if every component is dry.

STIRRING INSTRUCTION

FOOD	INSTRUCTION		PARTS	OPERATION TIME
	WEIGHT	REMARKS		
PORK	300g	boneless & skinless		10-20sec
BEEF	300g	boneless & skinless		10-20sec
ONION	300g	cut into four pieces		10-15sec intermittent operation
GARLIC	300g			10-15sec intermittent operation
CHILI	300g	cut into 4 cm per piece		5-10sec intermittent operation
TOMATO	300g	cut into four pieces		5-10sec intermittent operation
VEGETABLES	300g	cut into 3cm per piece		10-20sec intermittent operation
FRUIT	300g	cut into 2cm per piece		10-15sec
HAM SAUSAGE	300g	cut into 3 to four pieces		10-20sec

※ The stirring time depends.

SMART ELECTRICAL SUPPLIES CO.,LTD.
 52,54,56,58,60 Soi Phrayasuren 30 (Soi Saengal), Phrayasuren RD., Bangchan, Klongsamwa, Bangkok 10510, Thailand. Tel. (66)2-919-2311 Fax. (66)2-919-2400

Bang Pa-In

Fashion Island mall

Nopparat Hospital

TESCO Lotus Market

TOA

Driving school

Phrayasuren Soi 30

Ramintra Road

Ramintra 109

Bangna

Siam Park

makro

www.clartethailand.com